

Amphenol PCD SZ
ORIGINAL
PDF Format
R&D

NOTES:

1. PRODUCT DO NOT INCLUDE CONTACT, NEED TO BUY SEPARATELY.
2. THE POWER PIN:
2.5~4mm² CABLE P/N: EX30M4
6 mm² CABLE P/N : EX30M6
3. THE HVIL PIN :
0.5~0.75mm² CABLE P/N:EX16M1
4. SCOPE OF CABLE OUTSIDE DIAMETER OPTION:
CABLE OD =11~15mm;
5. TORQUE 1:7~10N.m \triangle
TORQUE 2:10~15N.m

5. PART NUMBER DESCRIPTION:

EX403 06 X M

CABLE SHIELD OPTION

M: MULTICORE SHIELDING CABLE

KEY OF CODING OPTION

- A: KEY A & RED($w^\circ=45^\circ$)
- B: KEY B & BLACK($w^\circ=90^\circ$)
- C: KEY C & YELLOW($w^\circ=180^\circ$)
- D: KEY D & GREEN($w^\circ=270^\circ$)
- E: KEY E & BLUE($w^\circ=315^\circ$)

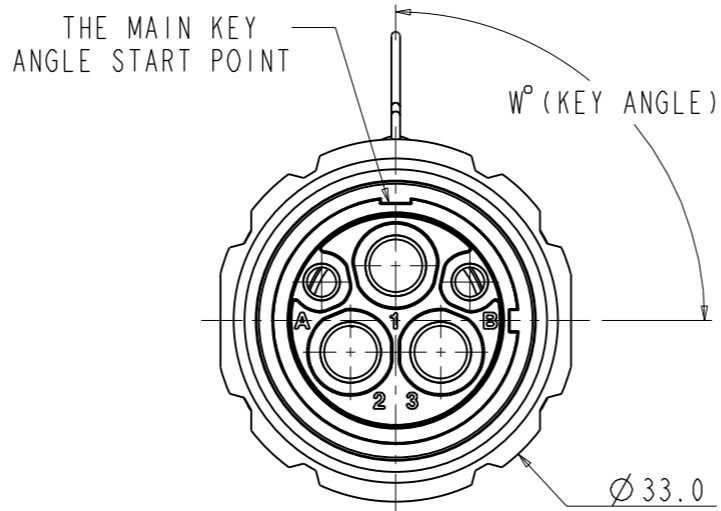

1~3 HOLES FOR $\phi 3.0$ POWER PIN
A, B HOLES FOR $\phi 1.6$ HVIL PIN

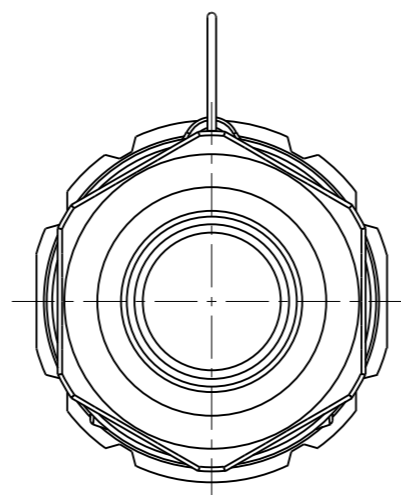
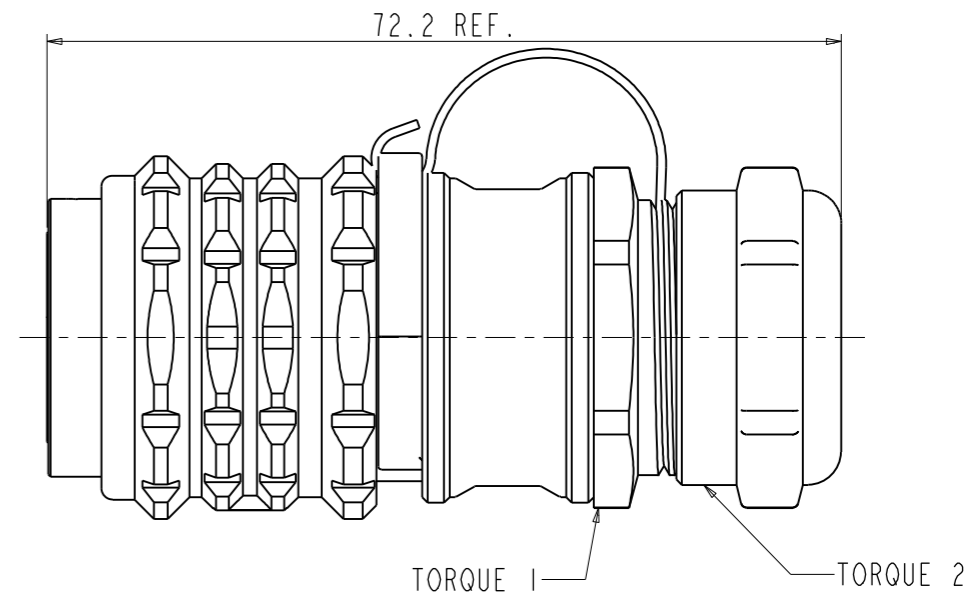

BACK VIEW

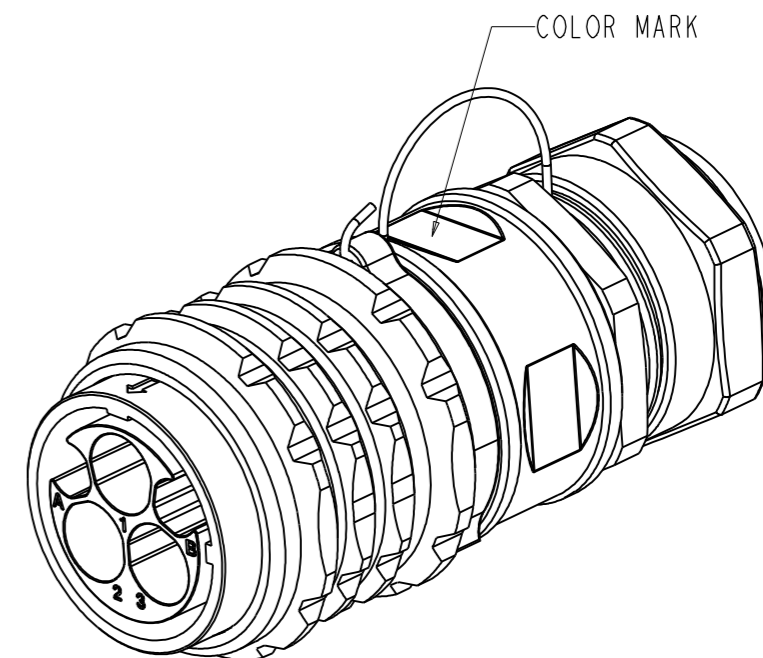

C-EX40306XM

C-EX40306XM

DIMENSIONS ANSI Y14.5M UNITS: MM Pro/E FILE	TOLERANCES .X ± 0.5 .XX ± 0.05 ANGLES $\pm 2^\circ$	PROJECTION 	Amphenol PCD Shenzhen			EX403 SERIES PLUG		
			ENGR			REV		
ORIGINAL	THIS DOCUMENT CONTAINS PROPRIETARY INFORMATION WHICH IS THE CONFIDENTIAL PROPERTY OF Amphenol PCD Shenzhen Co. Ltd Amphenol PCD Shenzhen Co. Ltd RESERVES THE RIGHT TO CLARIFY THIS DRAWING		CHKD		SIZE A3	DWG NO. C-EX40306XM	REV 4	
			APPD		CODE: 58982	SCALE: 3:2	SHEET 1 OF 2	

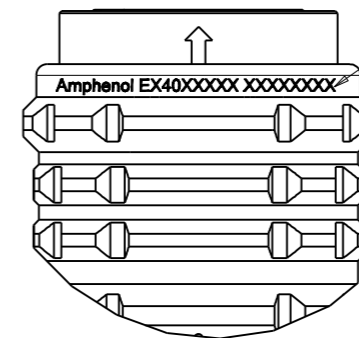
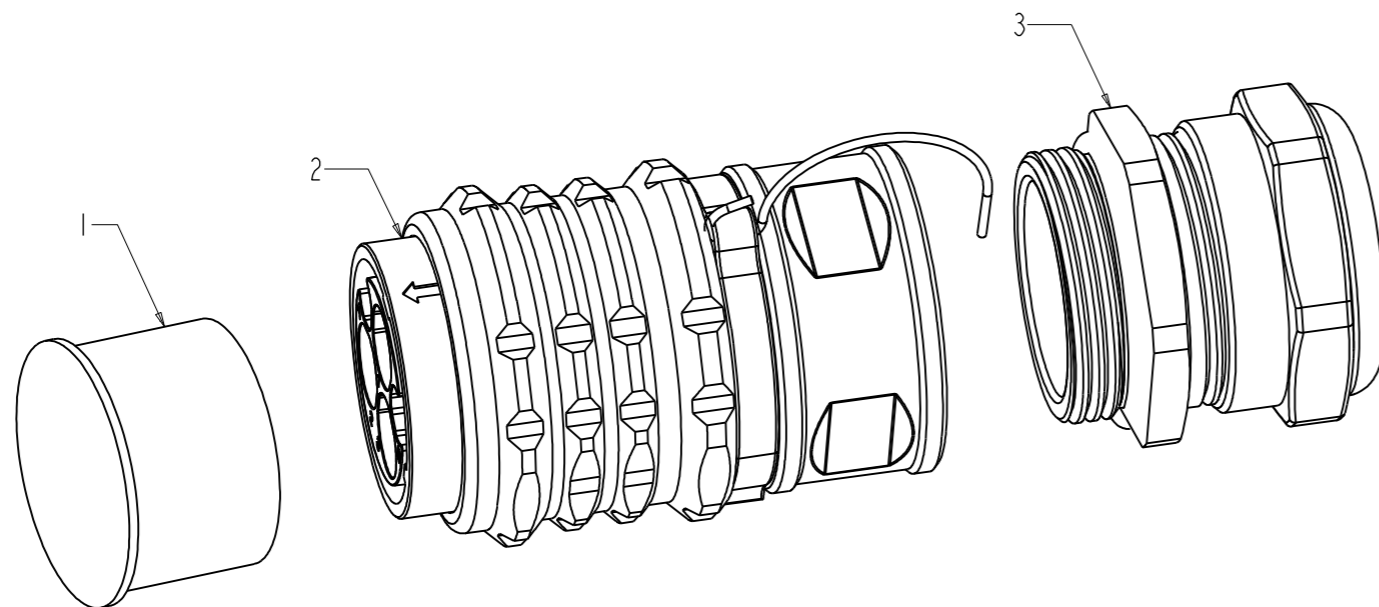

LETTER DESCRIPTION:
LOGO+P/N+THE TRACEABILITY CODE

6. TECHNICAL DATA TABLE

TECHNICAL DATA		
CURRENT RATING (6 mm ² SHIELDING CABLE)	40A @ AMBIENT 70°C	+
CURRENT RATING (4 mm ² SHIELDING CABLE)	32A @ AMBIENT 70°C	+
CURRENT RATING (2.5 mm ² SHIELDING CABLE)	23A @ AMBIENT 70°C	+
CURRENT RATING (0.5~0.75mm ² CABLE)	5A @ AMBIENT 70°C	+
RATING VOLTAGE (OVERVOLTAGE CATEGORY II POLLUTION DEGREE 2)	1000V DC	+
OPERATING TEMPERATURE	-40~125°C	
DIELECTRIC WITHSTANDING VOLTAGE	POWER CONTACT 3000V AC(RMS)	+
	HVIL CONTACT 660V AC(RMS)	+
INSULATION RESISTANCE	200MΩ MIN.@25°C NO CABLE	+
DURABILITY	50 CYCLES	◎
SHIELDING	YES	
WATERPROOF (MATED CONDITION)	IP 68 & IPX9K	+
PROTECTION LEVEL	IP2XB	+
AMBIENT TEMPERATURE	-40~70°C	
RoHS	YES	+

7. CONNECTOR SELECTION TABLE

ASSEMBLY P/N	ITEM	P/N	DESCRIPTION	Q'TY
EX40306XM	3	P01BN00307	GLAND	1
	2	SEE TABLE 1	MAIN BODY	1
	1	C422005984	DUST CAP	1

TABLE 1	P/N	DESCRIPTION
	P02B00009305	KEY E & COLOR: BLUE
	P02B00009304	KEY D & COLOR: GREEN
	P02B00009303	KEY C & COLOR: YELLOW
	P02B00009302	KEY B & COLOR: BLACK
	P02B00009301	KEY A & COLOR: RED

8. PIN CONTACTOR SELECTION TABLE
THE PIN NEED TO BUY SEPARATELY

P/N	DESCRIPTION	Q'TY
EX16M1	HVIL PIN FOR 0.5~0.75mm ² CABLE	2
EX30M4	POWER PIN FOR 2.5mm ² ~4mm ² CABLE	3
EX30M6	POWER PIN FOR 6mm ² CABLE	3

"+" CRITICAL CHARACTERISTICS
"◎" IMPORTANT CHARACTERISTICS

SIZE	DWG NO.	REV
A3	C-EX40306XM	4
CODE: 58982	SCALE: 3:2	SHEET 2 OF 2