

ASVG06SF1819SCBZLC

REV	ECN	DESCRIPTION	DATE	MODIFIED
1		PRE-RELEASE	2012.10.24	Andy
2		UPDATED	2014.08.13	Andy
3		UPDATED	2015.11.10	Wode

**Notes/注意:**

Material \ Finish 材料/电镀  
 Insert : Plastic  
 胶芯 : 塑料  
 Shell : Aluminum alloy/Black zinc  
 外壳: 铝合金/黑锌

Mechanical and Environmental data/机械和环境性能

Operating Temperature: -55°C ~ +125°C  
 工作温度: -55°C ~ +125°C  
 IP-Class: IP67(In Mating Condition)  
 防护等级: IP67(在配合条件下)  
 Durability: 500 cycles  
 机械寿命: 500次  
 Salt Spray:96H  
 盐雾: 96小时

Electrical data/电气性能

Rated Voltage (Vac rms): 500V  
 工作电压 (Vac rms): 500V  
 Rated Current: 13A Max  
 工作电流: 13A Max  
 Insulation Resistance: 2000 MΩ Min  
 绝缘电阻: 2000兆欧姆 Min  
 Contact Resistance: Less than 2.5 milliohms  
 接触电阻: 小于2.5毫欧姆

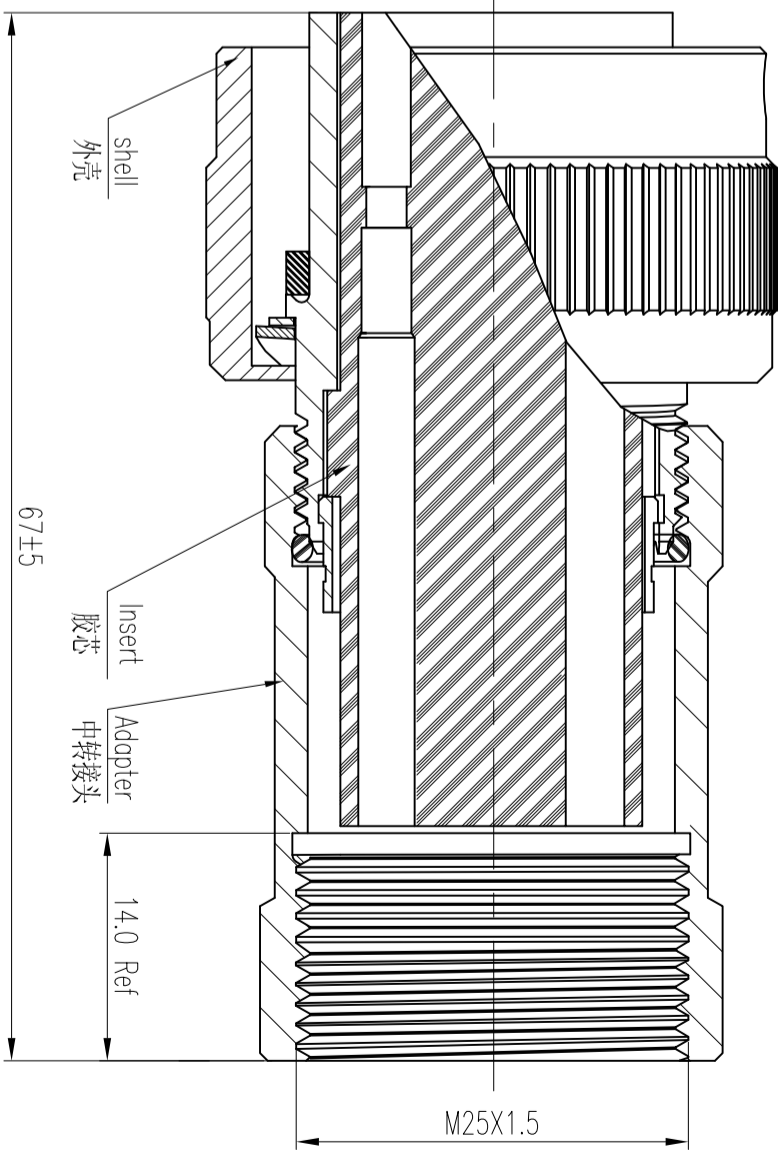
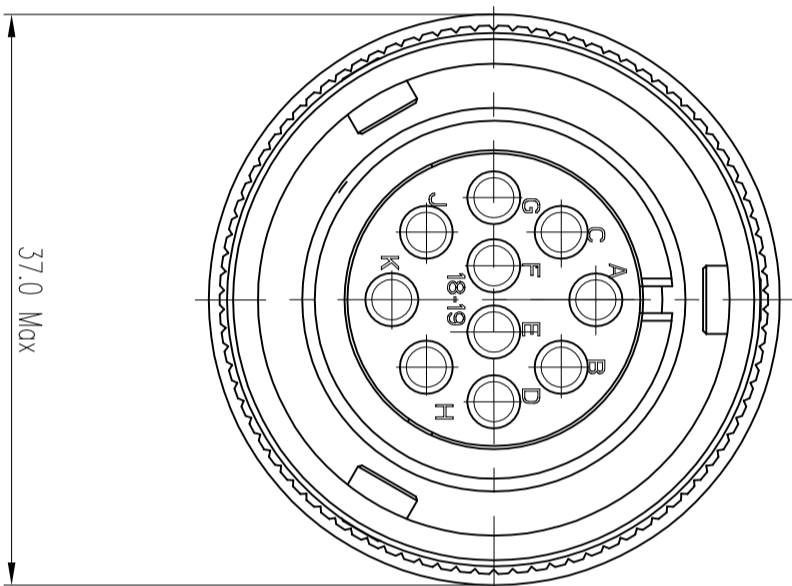

DIMENSIONS ANSI Y14.5M UNITS: MM CAD FILE	TOLERANCES X ± 0.5 .XX ±0.10 ANGLES ±0.5°	PROJECTION 	Amphenol Pcd Shenzhen		TITLE <b>CONNECTOR          PLUG 18-19S          BLACK ZINC PLATED</b>	
			ENGR	CHKD		SIZE A3
ORIGINAL NOT FOR CUSTOMER DISTRIBUTION	THIS DOCUMENT CONTAINS PROPRIETARY INFORMATION WHICH IS THE CONFIDENTIAL PROPERTY OF AMPHENOL PCD SHENZHEN			APPD	CODE: SCALE 1:1	SHEET 1 OF 1

ASVG06SF1819SCBZLC

ASVG06SF1819SCBZLC